



KITS



PUMPS



METERS



METERED NOZZLES



NOZZLES



WASTE OIL EQUIPMENTS

PIUSI HAND PUMP

FEATURES

- OPTIMIZED SUCTION CAPACITY
- STURDY CONNECTOR
- HEAVY DUTY LEVER
- FLUENT REVOLUTION
- HIGH EFFICIENCY
- ADJUSTABLE SUCTION PIPE
- DURABILITY
- SELECTED MATERIALS
- 100% TESTED

The PIUSI HAND PUMP is a rotary vane pump suitable for transferring low viscosity oils and diesel. Entirely designed, manufactured and certified in Italy this sturdy pump guarantees a professional performance. PIUSI HAND PUMP is also available in the version to dispense Windscreen and Anti-Freeze liquids.

PERFORMANCE

UP TO

38

L/100 REVOLUTIONS

FLOW RATE

AVAILABLE WITH

3M

LENGTH

DELIVERY HOSE



HAND PUMP FOR OIL



PIUSI HAND PUMP WINDSCREEN & ANTI-FREEZE

PACKAGING

CODE	WEIGHT		PACKAGING			N. BOXES/ EUROPALLET	
	KG	LBS	MM	PCS/PALLET	PCS/BOX		
FOO332500	2,1	4,6	350X170X140		1		
FOO332W00	3,1	6,8	300X300X180	-	1		



FILTRATION



FLUID MONITORING



TANK MONITORING



HOSE REELS



ACCESSORIES



MERCHANDISE

INDEX



AIR



ANTIFREEZE



AdBlue®



BIODIESEL



DIESEL



FOOD



GASOLINE



GREASE



KEROSENE



OIL



WATER



WINDSCREEN

CHART

PIUSI HAND PUMP

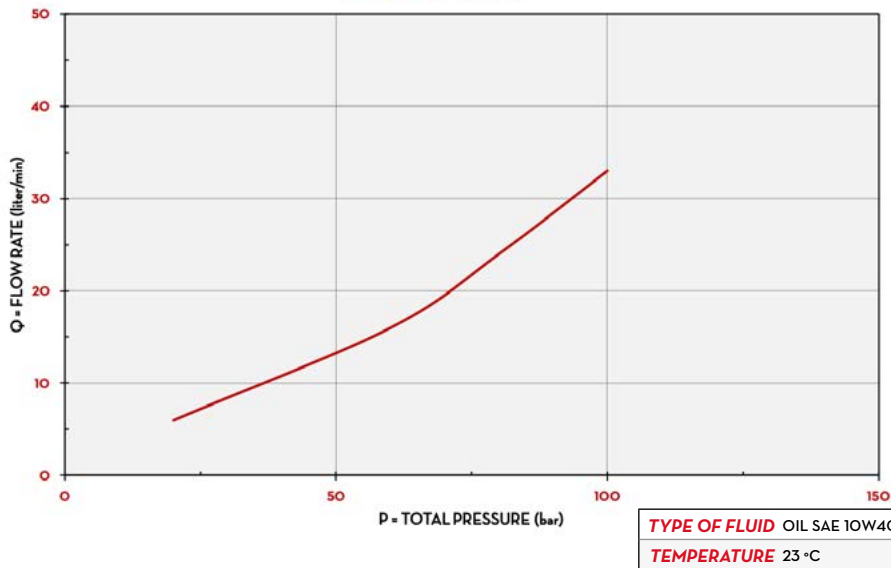

DIMENSIONS

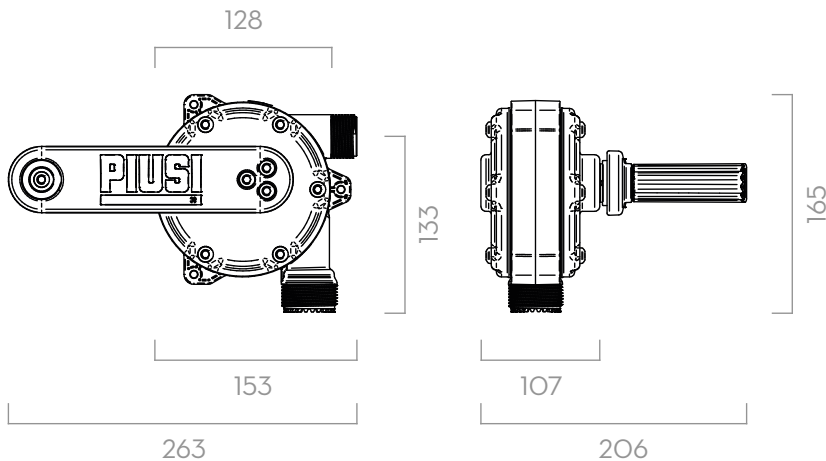

Dimensions expressed in millimeters

IN THE BOX

- PIUSI HAND PUMP
- SPOUT
- SUCTION PIPE
- DRUM CONNECTOR
- INSTRUCTION MANUAL

DETAILS

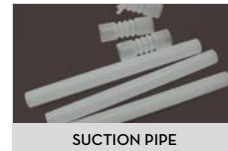

SUCTION PIPE



NON-SLIP HANDLE



HIGH QUALITY MATERIALS

MATERIALS

- BODY: STAINLESS STEEL, TECHNOPYMER
- ROTOR: TECHNOPYMER
- VANES: TECHNOPYMER

TECHNICAL DATA

CODE	DESCRIPTION	FLUIDS TYPE	CAPACITY PER 100 REVOLUTIONS		DRUM CONNECTOR	SUCTION TUBE	"S" SPOUT AND HOSE TAIL	DELIVERY HOSE LENGHT
			L	USG				M
FO0332500	PIUSI HAND PUMP 2" BSP		38	10	2" BSP	SI	SI	-
FO0332W00	PIUSI HAND PUMP WINDSCREEN & ANTI-FREEZE		38	10	2" BSP	SI	-	3M

PIUSI HAND PUMP