



SELF SERVICE MC 2.0

FEATURES

- STURDY STRUCTURE
- ALL-IN-ONE DISPENSER
- BUILT-IN LAN ADAPTER
- FRONT DOOR FOR EASY MAINTENANCE
- SSM 2.0 SOFTWARE REQUIRED
- IP55
- IDEAL FOR FUEL MANAGEMENT

The PIUSI SELF SERVICE MC 2.0 is a non-commercial fuel diesel dispenser able to fit any fleet management requirement. It requires the SSM 2.0 software to work. Equipped with 90 l/min continuous duty pump, it is suitable for any fleet dimension.

PERFORMANCE

UP TO 90 L/MIN	AC CONTINUOUS DUTY
FLOW RATE	POWER
± 0,5%	UP TO 1000
ACCURACY	USERS



ELECTRONIC METER INTEGRATED



SELF SERVICE MC 2.0

PACKAGING

CODE	WEIGHT		PACKAGING			N. BOXES / EUROPALLET	
	KG	LBS	MM	INCH	PCS/BOX	✈	🚚

COLUMN VERSION

FO074302B	75	165	1478X488X400	-	1	6	4
-----------	----	-----	--------------	---	---	---	---



FILTRATION



TANK MONITORING



HOSE REEL



ACCESSORIES



MERCHANDISE



ANY BIODIESEL



AIR



ANTIFREEZE



AdBlue®



BIODIESEL



DIESEL



FOOD



GASOLINE



GREASE



KEROSENE



OIL



WATER



WINDSCREEN

CHART

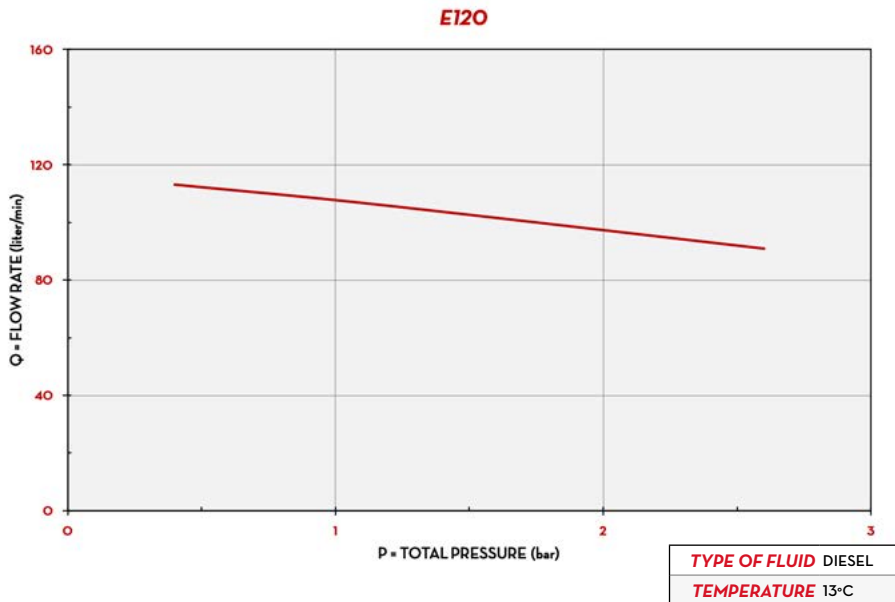

DIMENSIONS

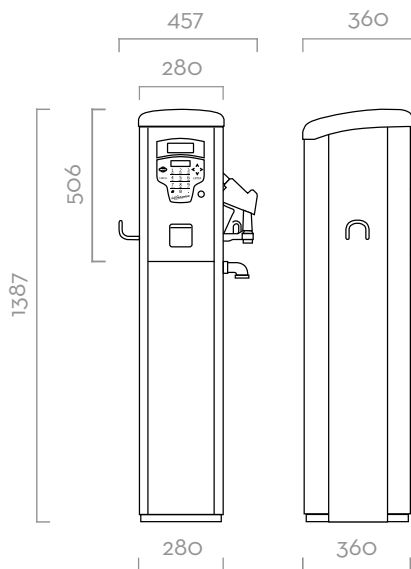

Dimensions expressed in millimeters

IN THE BOX

- SELF SERVICE MC 2.0 DISPENSER
- DELIVERY HOSE
- AUTOMATIC NOZZLE
- INSTRUCTION MANUAL

DETAILS



MATERIALS

- **PUMPS:**
E80 / E120 PAG. 104
- **METER:**
K600/3 PAG. 136
- **NOZZLE:**
AUTOMATIC NOZZLE PAG. 160
- **FILTER:**
WATER CAPTOR PAG. 172

TECHNICAL DATA

CODE	DESCRIPTION	FLUIDS TYPE	FLOW RATE		VOLTAGE			PUMP	METER	NOZZLE	FILTER		INLET	HOSE LENGTH	SELF SERVICE MANAGEMENT 2.0
			L/MIN	GPM	AC V/HZ DC VOLT	POWER WATT	AMP. MAX.				H2O FILTER	FILTERING CAPACITY			

COLUMN VERSIONS

FO074302B	SELF SERVICE 100 MC 2.0	D	90	24	230/50	1150	5,7	E120	K600	A120	YES	30µ	1" 1/2	4	REQUIRED
-----------	-------------------------	----------	----	----	--------	------	-----	------	------	------	-----	-----	--------	---	----------

SELF SERVICE MC 2.0