



KITS



PUMPS



METERS



METERED NOZZLES



NOZZLES



WASTE OIL EQUIPMENTS

VISCOMAT GEROTOR

FEATURES

- GEROTOR TECHNOLOGY
- PRESSURE REGULATOR
- FKM SEAL
- FLANGED PORTS

Created through PIUSI experience in the lubrication sector, VISCOMAT GEROTOR is a self-priming electric pump, designed to transfer oil at high flow rates. Thanks to the innovative system featuring radial backlash gears, the pump guarantees high performance and a compact design which help to ensure a long service life.

PERFORMANCE

UP TO 65 ± 3 l/min	UP TO 1000 CST
FLOW RATE	MAX. VISCOSITY
4-9 BAR	230/400 V 50HZ
PRESSURE REGULATOR*	VOLTAGE

*The pressure regulator does not function as a bypass.

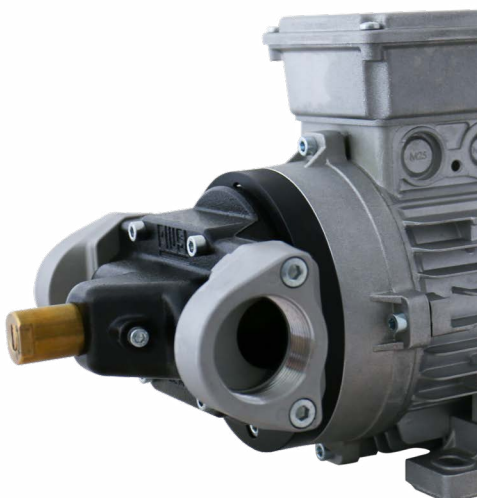
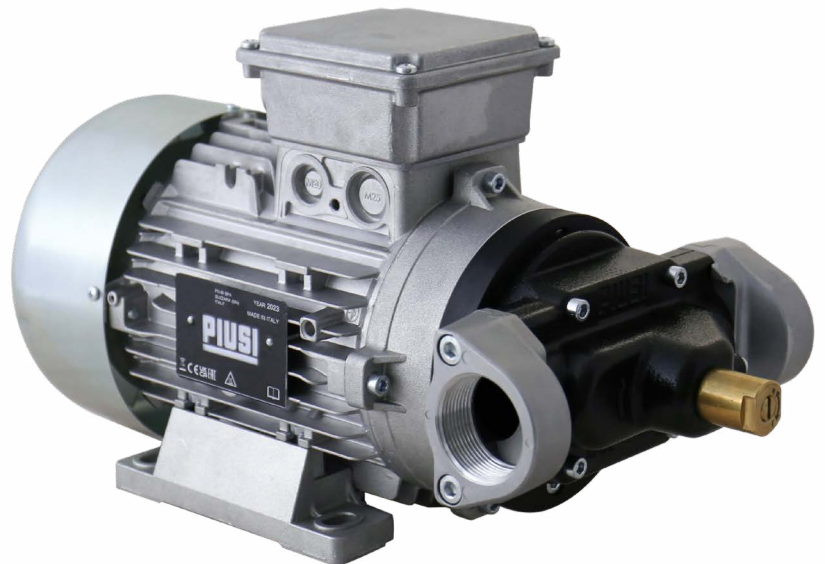

PACKAGING

CODE	WEIGHT		PACKAGING			
	KG	LBS	MM	INCH	PCS/PALLET	PCS/BOX
FO0334800	22,5	49,6			-	1



FILTRATION



FLUID MONITORING



TANK MONITORING



HOSE REELS



ACCESSORIES



MERCHANDISE



AIR



ANTIFREEZE



AdBlue®



BIODIESEL



DIESEL



FOOD



GASOLINE



GREASE



KEROSENE



OIL



WATER



WINDSCREEN

CHART

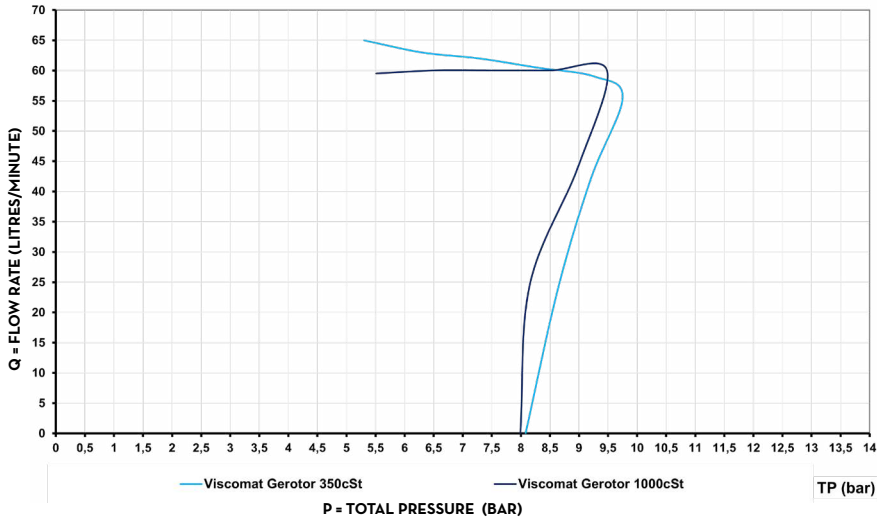

TYPE OF FLUID OIL SAE 80W90
TEMPERATURE 23 °C

DIMENSIONS

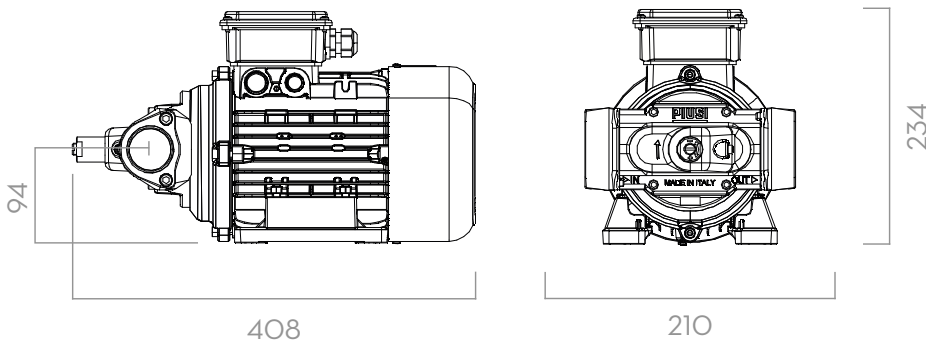

IN THE BOX

- VISCOMAT GEROTOR
- INSTRUCTION MANUAL

DETAILS

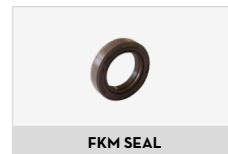

MATERIALS

- BODY/FLANGE: CAST IRON
- WET MATERIALS: CAST IRON, STEEL, BRASS
- GEARS/MOTOR SHAFT: STEEL
- REGULATING VALVE: BRASS
- LIP SEALING: FKM

COMPATIBLE FLUIDS

- OIL
- LUBRICANTS
- SILICONE LIQUIDS

TECHNICAL DATA

CODE	DESCRIPTION	FLOW RATE		WORKING PRESSURE		VOLTAGE				RPM	INLET OUTLET	FLANGES INCLUDED
		L/MIN	GPM	MAX.BAR	PSI	SINGLEPHASE MOTOR	THREEPHASE MOTOR	POWER WATT	AMP. MAX			
FO0334800	VISCOMAT GEROTOR 230-400V 50 HZ	65 ± 3	17 ± 1	9,5 ± 0,5	138 ± 7,2	230V/50Hz	400V/50Hz	2200	8,6/5	1350	Ø33 ± 1MM	1-1/2" BSP