



CAR FILLING



FUEL MANAGEMENT SYSTEMS



KITS



PUMPS



METERS



METERED NOZZLES

SELF SERVICE B.SMART

FEATURES

- ACCESS CONTROL AND MANAGE ADBLUE® DELIVERY
- 3D FILTER INTEGRATED
- COMPACT DESIGN
- NATIVE WITH B.SMART CLOUD SOFTWARE
- KIT UPGRADE 1.0/2018 AVAILABLE

SELF SERVICE B.SMART for AdBlue® is the updated version of the famous PIUSI AdBlue® dispenser integrated with the fuel management system B.SMART! Starting from today, you can manage the consumption of AdBlue® of your fleet with this new and innovative urea dispenser.

PERFORMANCE

UP TO

32 L/MIN

FLOW RATE

VOLTAGE

AC

POWER

±1%

ACCURACY

Upgrade your MC hardware to B.SMART with KIT UPGRADE SELF SERVICE 1.0/2018



SELF SERVICE B.SMART



PACKAGING

CODE	WEIGHT		PACKAGING			N. BOXES / EUROPALLET	
	KG	LBS	MM	INCH	PCS/BOX	✕	
FO0748020	48	105	1480X490X400	58.3X19.3X15.7	1		



NOZZLES



FILTRATION



TANK MONITORING



HOSE REEL



ACCESSORIES



MERCHANDISE

INDEX



AIR



ANTIFREEZE



AdBlue®



BIODIESEL



DIESEL



FOOD



GASOLINE



GREASE



KEROSENE



OIL



WATER



WINDSCREEN

CHART

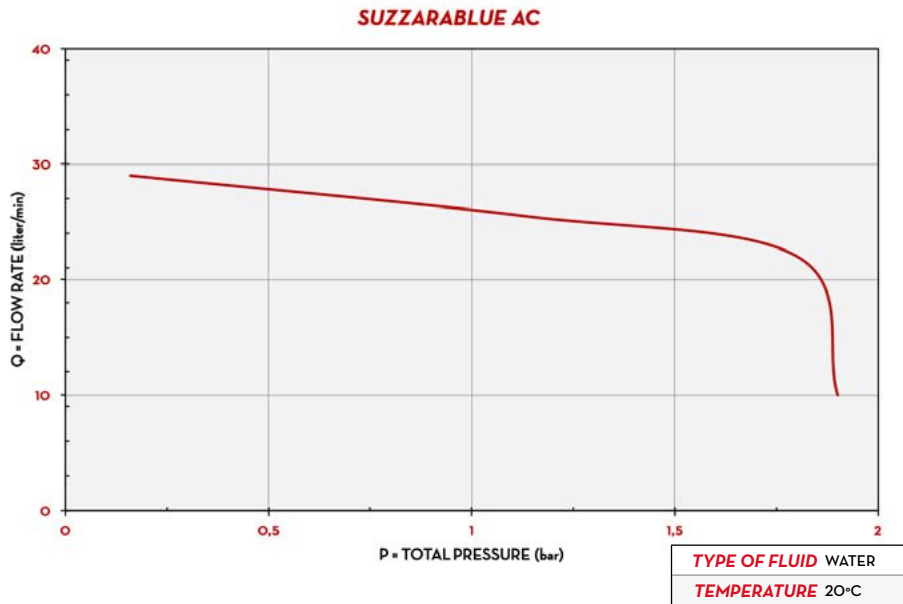

DIMENSIONS

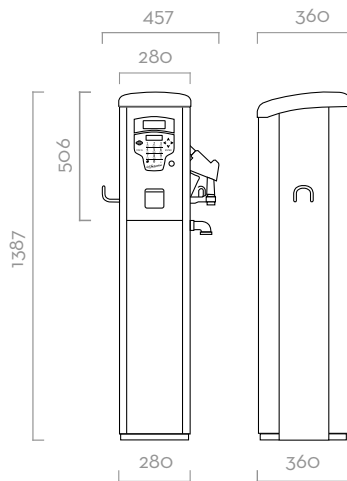

Dimensions expressed in millimeters

IN THE BOX

- SELF SERVICE B.SMART DISPENSER
- DELIVERY HOSE
- SB325_X NOZZLE
- DRIVER ACCESS ADD-ON
- INSTRUCTION MANUAL

DETAILS



3D FILTER



OCIO 2.0 ON REQUEST



B.SMART CLOUD SOFTWARE



B.SMART MOBILE APP

COMPONENTS

- **PUMP:**
SUZZARABLUE PUMP AC PAG. 70
- **METER:**
K24 PAG. 94
- **NOZZLE:**
SB325_X PAG. 116
- **FILTER:**
3D FILTER PAG. 126

TECHNICAL DATA

CODE	DESCRIPTION	FLUIDS TYPE	FLOW RATE		VOLTAGE			PUMP	METER	NOZZLE	FILTER	INLET	HOSE		
			L/MIN	GPM	AC V/HZ	DC VOLT	POWER WATT						AMP. MAX.	TYPE	LENGTH
FO0748020	SELF SERV ADBLUE 230V B.SMART 10 ACCESS		34	8,9	230 V	50 HZ	400 W	1.95 A	SUZZARABLUE AC	K24	SB325_X	YES	3/4"	6 M	1"

SELF SERVICE B.SMART

B.SMART DISPENSERS

31