



CAR FILLING



FUEL MANAGEMENT SYSTEMS



KITS



PUMPS



METERS



METERED NOZZLES

MP 130

FEATURES

- IN/OUT INTERCHANGEABLE
- BUILT-IN DIFFUSER
- SUITABLE FOR SUBMERSIBLE INSTALLATION
- HEAVY DUTY
- EASY TO FIT
- STURDY DESIGN

The PIUSI MP 130 is a pneumatic diaphragm pump suitable for transferring AdBlue®. Thanks to its small size, this pump is easy to fit. It is self-priming and it can run dry without damage.

PERFORMANCE

UP TO

50 L/MIN

FLOW RATE

MAX CAPACITY

5M

SELF PRIMING

MAX

7 BAR

AIR SUPPLY

PRESSURE

MAX

Ø 4MM

PASSING SOLID



MP 130



PACKAGING

CODE	WEIGHT		PACKAGING		
	KG	LBS	MM	INCH	PCS/BOX
FOO208POO	3,6	7,9	220X310X320	8,7X12X12,6	1



NOZZLES



FILTRATION



TANK MONITORING



HOSE REEL



ACCESSORIES



MERCHANDISE

INDEX



AIR



ANTIFREEZE



AdBlue®



BIODIESEL



DIESEL



FOOD



GASOLINE



GREASE



KEROSENE



OIL



WATER



WINDSCREEN

CHART

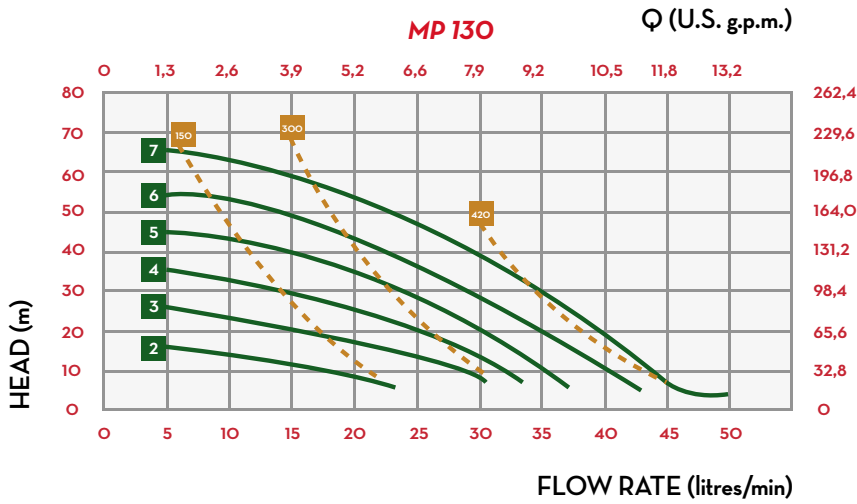

IN THE BOX

- MP 130 PUMP
- INSTRUCTION MANUAL

DIMENSIONS

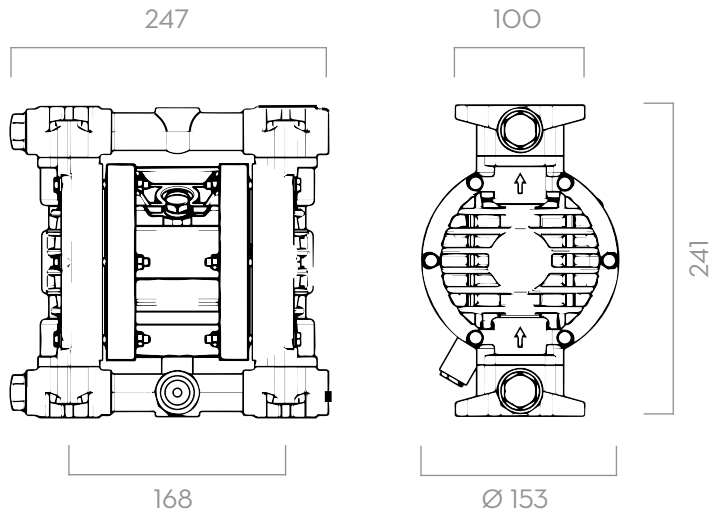

Dimensions expressed in millimeters

DETAILS



HEAVY DUTY MATERIALS



TECHNOPOLYMER BODY



STURDY DESIGN

MATERIALS

- BODY: TECHNOPOLYMER
- SIDE PARTS AND COLLECTORS: POLYPROPYLENE
- DIAPHRAGM: EPDM

TECHNICAL DATA

CODE	DESCRIPTION	FLUIDS TYPE	PUMP BODY	IN / OUT	FLOW RATE L/MIN	MEMBRANE TYPE	DIAPHRAGM AIR SIDE/ FLUID SIDE	BALLS	BALL SEATS*	O-RING*	INTAKE / DELIVERY CONNECTION	AIR CONNECTION	MAX SELF-PRIMING CAPACITY	MAX HEAD**	MAX AIR SUPPLY PRESSURE	MAX Ø OF PASSING SOLID
													M	M	BAR	MM
FOO208POO	PIUSI MP 130		POLYPROPYLENE	1/2" G	50	DOUBLE	PTFE/ HYTREL	PTFE	POLYPROPYLENE	PTFE	G 1/2" F	G 3/8" F	5	70	7	4

(*) ON REQUEST WE CAN PROVIDE MEMBRANES, BALLS, BALL SEATS AND O-RINGS IN DIFFERENT MATERIALS.
 (**) THE VALUE DEPENDS ON THE CONFIGURATION OF THE PUMP

MP 130