



FUEL MANAGEMENT SYSTEMS



DISPENSERS



KITS



PUMPS



METERS



NOZZLES

ST 200 DC

FEATURES

- STURDY STRUCTURE
- COMPACT DESIGN
- READY TO USE
- HIGH RELIABILITY
- HEAVY DUTY

PIUSI ST 200 DC is a 24V portable dispensing unit for high flow applications. The low weight of the unit makes it easy to handle and suitable for operating on worksites in every condition; both on tanks or for mobile applications. Thanks to the mechanical meter K700, this sturdy dispenser guarantees the maximum precision (on request).

PERFORMANCE

UP TO

185 L/MIN

FLOW RATE

24V

VOLTAGE

POWER

20 MIN

(40MIN OFF)

DUTY CICLE



ST 200 DC



PACKAGING

CODE	WEIGHT		PACKAGING		
	KG	LBS	MM	INCH	PCS/BOX
FO0318000	18	40	480X370X265	18,9X14,6X10,4	1



FILTRATION



TANK MONITORING



HOSE REEL



ACCESSORIES



MERCHANDISE



ANY BIODIESEL



AIR



ANTIFREEZE



AdBlue®



BIODIESEL



DIESEL



FOOD



GASOLINE



GREASE



KEROSENE



OIL



WATER



WINDSCREEN

CHART

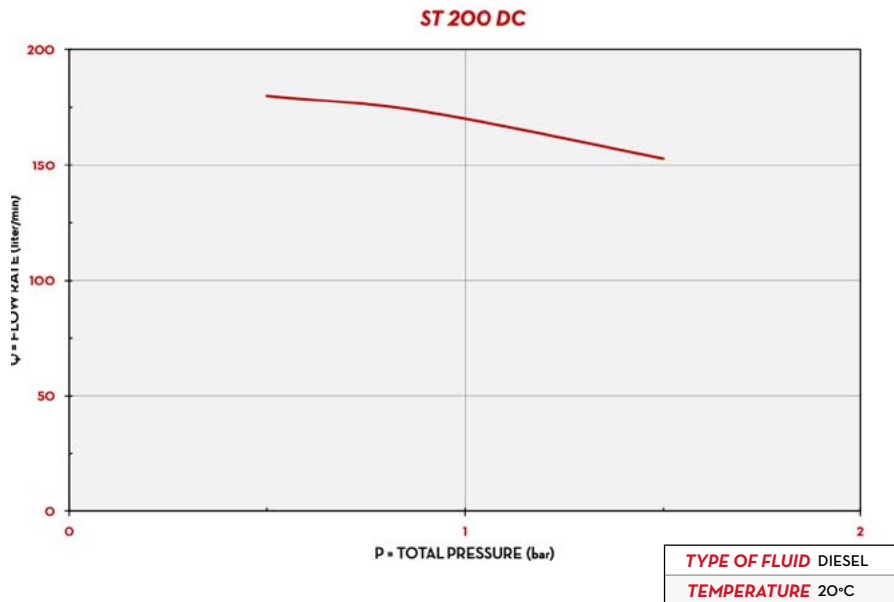

IN THE BOX

- ST 200 DC UNIT
- ELECTRIC CABLE WITH CLAMPS
- INSTRUCTION MANUAL

DETAILS



ON/OFF SWITCH

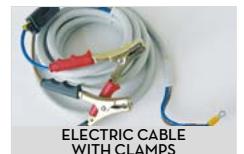

ELECTRIC CABLE WITH CLAMPS

DIMENSIONS

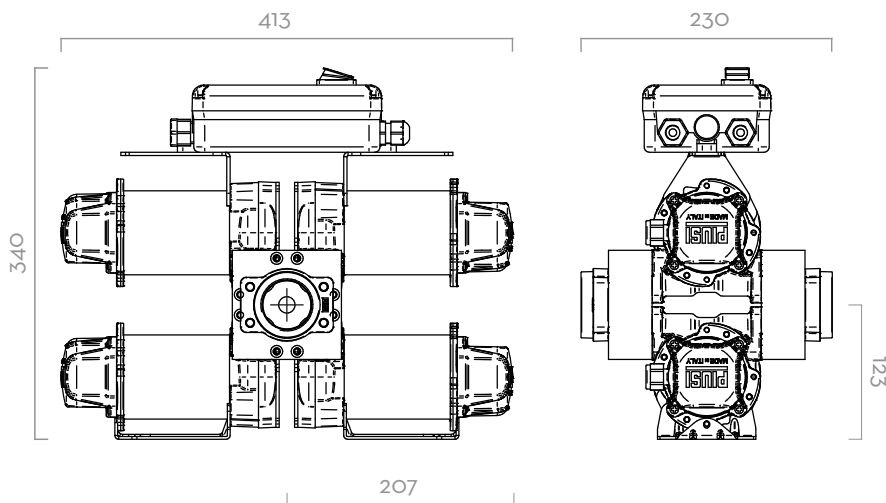

Dimensions expressed in millimeters

MATERIALS

- BODY: CAST IRON
- ROTOR: SINTERED STEEL
- VANES: ACETAL RESIN
- SEAL: NBR
- SHAFT: STEEL

TECHNICAL DATA

CODE	DESCRIPTION	FLUIDS TYPE	FLOW RATE		VOLTAGE			DUTY CICLE	PUMP		MAX PRESSURE	OUTLET
			L/MIN	GPM	AC V/HZ	DC VOLT	POWER WATT		AMP. MAX.	MINUTES		
FO0318000	ST 200 DC 24 V	D	185	42-48	24	1200	50	30	BYPASS 3000	4	2	1" 1/2

ST200 DC