



KITS



PUMPS



METERS



METERED NOZZLES



NOZZLES



WASTE OIL EQUIPMENTS

MA 130

FEATURES

- IN/OUT INTERCHANGEABLE
- LONG LIFE DIAPHRAGM
- BUILT-IN DIFFUSER
- SUITABLE FOR IMMERSED INSTALLATIONS
- HEAVY DUTY
- EXPLOSION PROOF (EX ZONE 2)
- STURDY DESIGN

The PIUSI MA 130 is a pneumatic diaphragm pump suitable for transferring high viscosity fluids and waste oils. Thanks to its small size this pumps is easy to fit in any working environment.

PERFORMANCE

UP TO 90 L/MIN	MAX 7 BAR
FLOW RATE	AIR PRESSURE
MAX CAPACITY 5 M	MAX Ø 4MM
SELF PRIMING	PASSING SOLID



MA 130



PACKAGING

CODE	WEIGHT		PACKAGING			
	KG	LBS	MM	INCH	PCS/PALLET	PCS/BOX
FO0208A00	4	8,8	220X310X320	8,7X12,2X12,6		1



FILTRATION



FLUID MONITORING



TANK MONITORING



HOSE REELS



ACCESSORIES



MERCHANDISE

INDEX



AIR



ANTIFREEZE



AdBlue®



BIODIESEL



DIESEL



FOOD



GASOLINE



GREASE



KEROSENE



OIL



WATER



WINDSCREEN

CHART

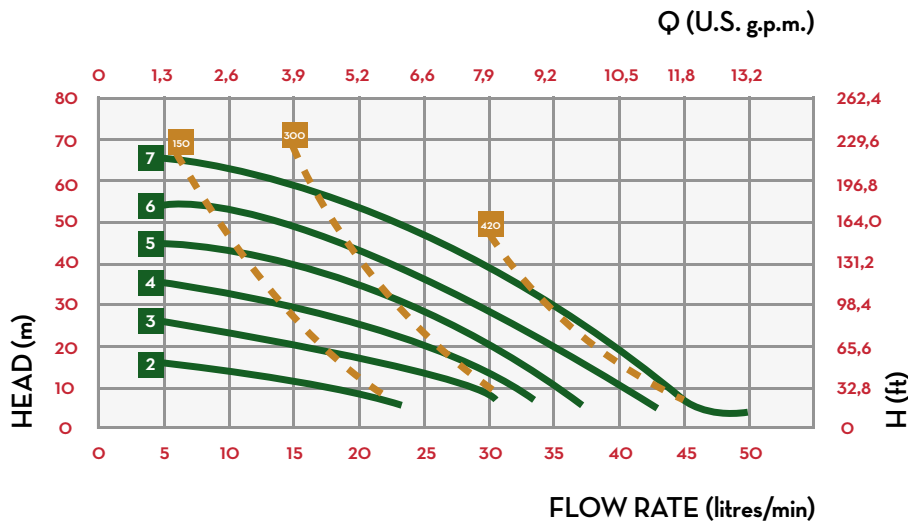

IN THE BOX

- MA 130 PUMP
- INSTRUCTION MANUAL

DETAILS



HEAVY DUTY MATERIALS



TECHNOPOLYMER BODY



EASY TO FIT

MATERIALS

- BODY: TECHNOPOLYMER
- FITTINGS: ALLUMINIUM
- DIAPHRAGMS: TECHNOPOLYMER

DIMENSIONS

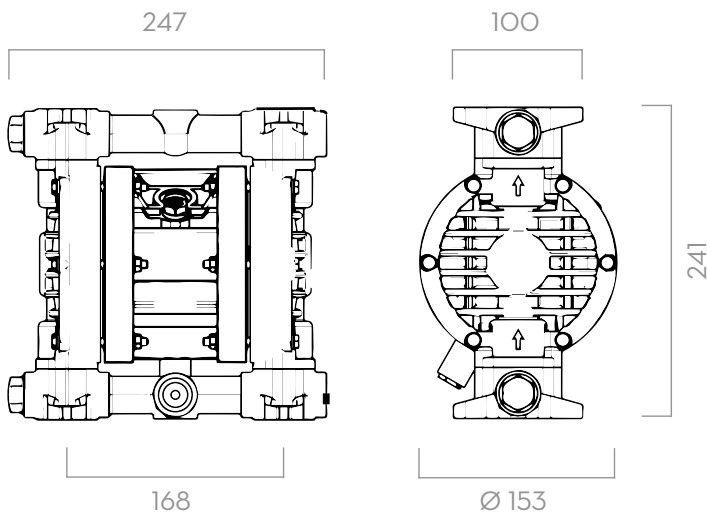

Dimensions expressed in millimeters

TECHNICAL DATA

CODE	DESCRIPTION	FLUIDS TYPE	PUMP BODY	IN / OUT	FLOW RATE L/MIN	MEMBRANE TYPE	DIAPHRAGM	BALLS	BALL SEATS*	O-RING*	INTAKE / DELIVERY CONNECTION	AIR CON-NECTION	MAX SELF-PRIMING CAPACITY	MAX HEAD**	MAX AIR SUP-PLY PRESSURE	MAX Ø OF PASSING SOLID
													M	M	BAR	MM
FOO208A00	PIUSI MA 130	O D	ALLUMINIUM	1/2" G	50	SINGLE	NBR	NBR	ALLUMINIUM	NBR	G 1/2" F	G 3/8" F	5	70	7	4

(*) ON REQUEST WE CAN PROVIDE MEMBRANES, BALLS, BALL SEATS AND O-RINGS IN DIFFERENT MATERIALS.
 (**) THE VALUE DEPENDS ON THE CONFIGURATION OF THE PUMP

MA 130